

DIMENSIONS

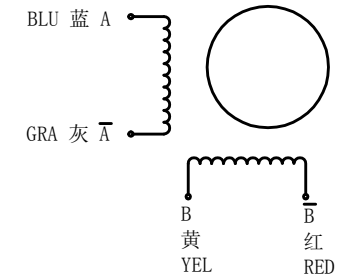
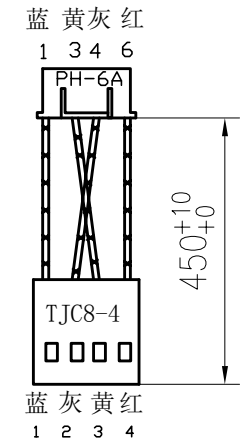
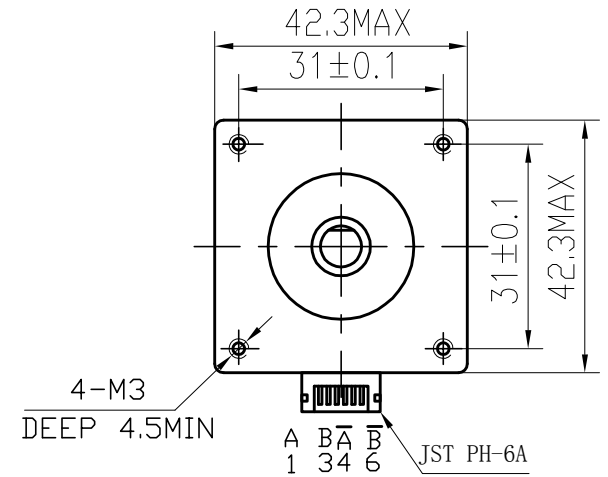
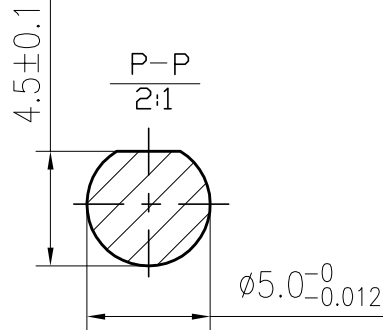
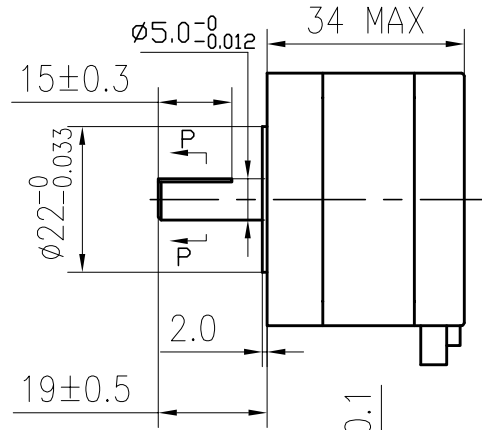

SPECIFICATIONS unit=mm

PHASE	相数	2 PHASE	COMMENT
STEP ANGLE	步距角	$1.8 \pm 5\% \text{ } ^\circ / \text{STEP}$	
VOLTAGE	静电压	3.12 V	
CURRENT	电流	1.3 A/PHASE	
RESISTANCE	电阻	$2.4 \pm 10\% \text{ } \Omega / \text{PHASE}$	
INDUCTANCE	电感	$2.8 \pm 20\% \text{ mH/PHASE}$	
HOLDING TORQUE	静转矩	28 N.cm Min	
DETENT TORQUE	定位转矩	1.6 N.cm Max	
INSULATION CLASS	绝缘等级	B	
LEAD STYLE	引出线规格	AWG24 UL1007	
ROTOR TORQUE	转动惯量	35 g.cm^2	

				17HS3413L19P1-X1		SYS MOTOR	
A	更改单号	签名	日期	等级标记	重量		
设计	ANDY	2015.3.13					
审核							
工艺							
标准化				1 共 张			
批准							
				技术规格书			

旧底图号

底图总号

日期 签名

格式 (1)

制图:

描图:

幅面: 3#