

尺寸/Dimensions 单位/Unit:mm

ROHS COMPLIANT

CE

24IP2100-03

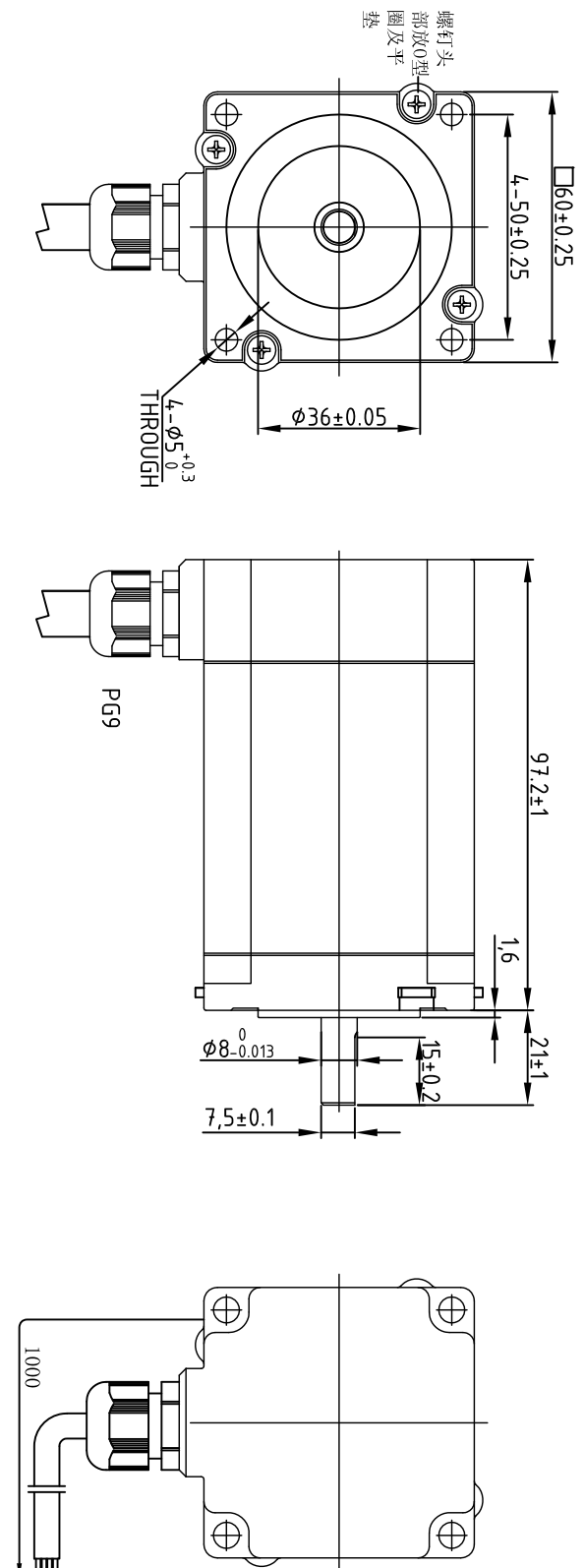

电动机规格书/Motor Specification

相数/Number Of Phase	2
基本步距角/Basic Step Angle	1.8°
基本步距角误差/空载/Positional Accuracy(no-load)	±0.09°以下/Max
额定电流/相/Rated Current(Phase)	3.0A
电阻(相)/Resistance(Phase)@20℃	1.3Ω±15%
电感(相)/Inductance(Phase)@1kHz	5.4mH±20%
保持力矩/Holding Torque	3.0N·m
转子惯量/Rotor Inertia	≈690g·cm ²
质量/Mass	≈1.4kg
空向跳动力/最大/Radial Play(Max)	0.025mNload/负载 4.50N
轴向跳动力/最大/Axial Play(Max)	0.075mNload/负载 920μ
额定工作状态/Duty	连续/Continuous
绝缘耐压/Dielectric Strength	500V AC
绝缘等级(UI)/Insulation Class(UI)	100MΩ以上/Min
寿命(小时/Life(hours))	80K以下/Max
温升(Temperature Rise)	5000以上/Min
使用温度范围/Operation Ambient Temperature	0℃~+50℃
使用湿度范围/Operation Ambient Humidity	20%RH~90%RH
保存温度范围/Storage Temperature	-20℃~+70℃
保存湿度范围/Storage Ambient Humidity	15%RH~95%RH
防水等级/Waterproof Grade	IP65

线图/Wiring Diagram

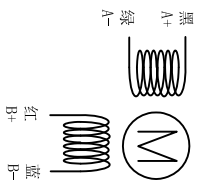

励磁顺序 (2相励磁) Phase Sequence(2 Phase Exciting)

		CW						CCW
Step	A	B	A̅	B̅	A	B	A̅	B̅
1	+	+	-	-	+	+	-	-
2	-	+	+	-	-	+	-	+
3	+	-	-	+	+	-	-	+
4	-	-	+	+	-	-	+	-
5	+	+	-	-	+	+	-	-

SYS MOTOR

铭牌内容/Label Description



设计/Designed	日期/Date	制图/Drawn	YY	20181113	比例/Scale	1:2	页/Sheet	1/1
批准/Approved		审核/Checked			公差 Tolerance	±0.2	NO.	056128
设计/Designed		制图/Drawn			表面处理 Finish			

1

2

3

4

5

6

7

8