

HYBRID STEPPING MOTOR MOD. 17HS8415NP1

□ COLORS OF LEAD WIRES

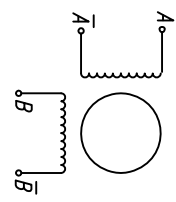

□ DIMENSIONS unit=mm

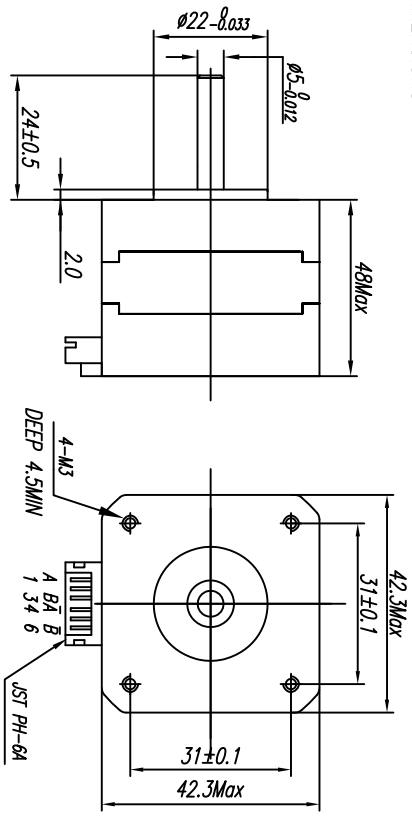

□ SPECIFICATIONS

PHASE	相数	2	PHASE	COMMENT
STEP ANGLE	步距角	$1.8 \pm 5\%$	*/STEP	
VOLTAGE	静电压	9	V	
CURRENT	电流	1.5	A/PHASE	
RESISTANCE	电阻	2.8	$\pm 10\% \Omega$ /PHASE	
INDUCTANCE	电感	4.0	$\pm 20\% \text{mH}$ /PHASE	
HOLDING TORQUE	静转矩	50	N.cm Min	
DETENT TORQUE	定位转矩	2.6	N.cm Max	
INSULATION CLASS	绝缘等级	B		
LEAD STYLE				

设计	审核	技术规格书		SYS MOTOR	
工艺	批准	版本	共	张	
1	2	3	4		